SPIDERMAN, PATENTS AND ROYALTY ARRANGEMENTS: UNTANGLING
WHAT *KIMBLE* MEANS IN PRACTICE AND HOW TO WEAVE AROUND
BRULOTTE'S ECONOMIC CONSTRAINTS

Nebyu Retta*

I. Introduction

Article I, Section VIII of the U.S. Constitution fosters and promotes innovation and new discovery.¹ The Framers gave Congress the authority to give inventors the exclusive right to secure their discoveries for a limited time.² Approximately one year later, President George Washington signed The Patent Act of 1790; a bill that laid the foundation for today's modern American patent system.³ In 1964, the U.S. Supreme Court established a firm and bright-line rule in *Brulotte v. Thys*, holding that parties forming private contracts for payments of royalties beyond the patent term-limit were unen-

* J.D. Candidate, Suffolk University Law School, 2016.

¹ See U.S. CONST. art. I, § 8, cl. 8 (expressing Congress's legislative power to protect the writings of authors and the discoveries of inventors).

² See *id.* (vesting in Congress the power to grant patent rights). "To promote the progress of science and useful arts, by securing for limited times to authors and inventors the exclusive right to their respective writings and discoveries." *Id.*

³ See Patent Act of 1790, ch. 7, 1 Stat. 109 (repealed 1793) (defining U.S. patent law); see also Press Release, U.S. Patent and Trademark Office, The U.S. Patent System Celebrates 212 Years (Apr. 9, 2002) (on file with author) (explaining subject matter of first patent act signed on April 10, 1790).

forceable patent misuse.⁴ But over the years, as modern patent law has commercially advanced, concerns surrounding royalty agreements became a paramount issue.⁵ As a result, the *Brulotte* decision has been widely criticized by academics and legal scholarship.⁶

Despite the legal community's growing disdain for *Brulotte*, on June 22, 2015, the U.S. Supreme Court in *Stephen Kimble et al. v. Marvel Entertainment*, decided not to strike down the precedent, on the basis of *stare decisis*.⁷ The Court upheld the rule established in *Brulotte*, that post-patent term royalties are unlawful *per se*, even where parties enter into voluntary agreements and equal bargaining power exists among them.⁸ Although, the decision in *Kimble* re-etched *Brulotte*'s bright-line, the Court hinted at creative ways parties can structure agreements without disturbing the precedent.⁹

This Note discusses four ways patent licensors can draft agreements without infringing on *Brulotte*. These include: (1) amortization agreements—where parties set a royalty based on sales during the patent term, and remunerating it over a longer period extend-

⁴ See *Brulotte v. Thys Co.*, 379 U.S. 29, 33-34 (1964) (“[w]e share the views . . . that after expiration of the last of the patents incorporated in the machines ‘the grant of patent monopoly was spent’ and that an attempt to project it into another term by continuation of the licensing agreement is unenforceable”). The Court held that patentees could control the manufacturing, use, and sale of patented products with license agreements; however, they could not use license agreements to control the resale price of patented products because this qualifies as patent misuse. *Id.*

⁵ See *Sears v. Stiffel Co.*, 376 U.S. 225, 230 (1964) (delineating that the tension between patent law and antitrust law has been at the helm of federal jurisprudence for centuries).

⁶ See Marshall Leaffer, *Patent Misuse and Innovation*, 10 J. HIGH TECH. L. 142, 154 (2010) (showing that the ruling was widely criticized by academics and economic theorists). Nonetheless, fifty years later, in a subsequent opinion affirming *Brulotte*, the Supreme Court listed some of the criticism suggesting that the case should be overruled. *Id.*

⁷ See *Kimble et al. v. Marvel Entertainment LLC*, 135 S. Ct. 2401, 2405 (2015) (determining that *Brulotte* will be upheld on the basis of *stare decisis*).

⁸ See Shanton J. Lovenworth & Andrew Dolak, *Supreme Court: Status Quo for Patent License Royalty Term*, O'MELVENY & MYERS LLP (June 23, 2015), archived at <https://perma.cc/3NBH-V4QS> (pointing out how *Brulotte* and *Kimble* both invalidated voluntary contracts structured around post-patent term royalty agreements).

⁹ See *Kimble*, 135 S. Ct. at 2408 (indicating ways parties can structure their agreements that will help them achieve similar desirable results).

ing passed the end of the patent term; (2) patent groupings—where a large family of patents are licensed, royalties may run for all patents in the portfolio until the expiration of the last patent terminates; (3) hybrid agreements—which encompasses both the right to use the patent as well as trade secrets, and the licensor provides technical support, or some other source of value to the licensee throughout the term of the license, which may extend beyond the term of the patent and; (4) business arrangements such as joint ventures—which would enable parties to share the risks and rewards of commercializing an invention.¹⁰ In addition, this Note seeks to dispel some of the misconceptions surrounding the limitations posed by the aforementioned precedents.¹¹ Part II examines the history, development and policy objectives of the modern patent system—including the lasting jurisprudential footprint left behind by *Brulotte*.¹² Part III provides a discussion of *Kimble*, including the scope of limitations regarding patent royalty agreements.¹³ Part IV analyzes and advances four legal royalty arrangements that circumvent *Brulotte* to ultimately achieve the same ends advocated by the petitioners in *Kimble*.¹⁴ Ultimately, this Note will conclude that the Supreme Court decision in *Kimble* signified that *Brulotte* hardly set economic constraints on licensing arrangements because other legal agreements may be implemented involving ongoing payments for patent rights.¹⁵

II. History

A. A Brief Introduction to US Patent Law

Since 1953, the patent laws have been revised and codified under Title 35 of the United States Code.¹⁶ The Patent Act, as

¹⁰ See *id.* (specifying the four ways enumerated in *Kimble* that parties can structure licensing agreements without violating the bright-line rule in *Brulotte*).

¹¹ See *Brulotte*, 379 U.S. at 30 (describing the *Brulotte* holding and precedent set forth); see also *Kimble*, 135 S. Ct. at 2405 (discussing the refusal of the Court to overturn *Brulotte*).

¹² See *infra* Part II.

¹³ See *infra* Part III.

¹⁴ See *infra* Part IV.

¹⁵ See *infra* Part V.

¹⁶ See 35 U.S.C. (1952) (referring to the Patent Act enacted by Congress on July 19, 1952).

amended, broadly grants to: “[w]hoever invents or discovers any new and useful process, machine, manufacture, or composition of matter, or any new and useful improvement thereof”¹⁷ As defined by the statute, patents are broadly classified into categories of design, utility or plants.¹⁸ An inventor may apply to obtain a patent to an invention from the United States Patent and Trademark Office (“USPTO”).¹⁹ Once the patent is issued and without aid of the USPTO, the patent holder has the right to exclude others²⁰ from making using, selling or importing the invention during the term of the patent.²¹ Under the Patent Act, a patent holder may license his or her property interest in an invention, in writing, prior to its expiration.²² Likewise, a patentee may license the patent for any royalty, or upon any condition, which is normally and reasonably adapted to the patent policy of securing to the inventor the rewards of the invention.²³ Accordingly, the royalties must be reasonably related to the licensee’s use of the patented invention.²⁴

¹⁷ See 35 U.S.C. § 101 (1952) (detailing the scope of coverage under the Patent Act).

¹⁸ See *General Information Concerning Patents*, U.S. PAT. AND TRADEMARK OFF. (Oct. 2014), archived at perma.cc/N65F-SQA9 (classifying the three categories of patents).

¹⁹ See *id.* (describing the procedural requirement in order to obtain a patent).

²⁰ See *id.* (introducing the right of exclusion patentees are afforded upon the issuance of a patent).

²¹ See STEPHEN M. MCJOHN, *INTELLECTUAL PROPERTY: EXAMPLES & EXPLANATIONS* 326-27 (Vicki Been et al. eds., 4th ed. 2012) (explaining broadly what the right of exclusion for patent holders entail).

²² See 35 U.S.C. § 261 (1952) (stating that “[t]he applicant, patentee or his assigns or legal representatives may . . . grant and convey an exclusive right under his application for patent . . .”).

²³ See 35 U.S.C. § 100 (1952) (defining other key words found throughout the patent statutes). “The term patentee includes not only the patentee to whom the patent was issued but also the successors in title to the patentee.” *Id.* “The term “claimed invention” means the subject matter defined by a claim in a patent or an application for a patent.” “The term “inventor” means the individual or, if a joint invention, the individuals collectively who invented or discovered the subject matter of the invention. *Id.* See also *U.S. v. General Electric Co.*, 272 US 476, 488 (1926) (pronouncing that patentees have a right to receive royalties from licensees); Andrew Clark, *Does Dolly Deserve Defense? An Analysis of the Patentability of Cloned Livestock*, 15 J. HIGH TECH L. 135, 137 (2014) (outlining terms and interpretable subject matter under the Patent Act).

²⁴ See *Zenith Radio Corp. v. Hazeltine Research Inc.*, 395 U.S. 100, 136 (1969) (noting that royalties must not be too far attenuated from licensee’s use of patented

B. Patent Rights Under the US Patent System

In 2013, President Barack Obama signed into law, changing what has long been known as a uniquely American approach to patent law—the “first to invent” to a “first-inventor-to-file” system.²⁵ The antecedent to this law came in 1999, when Congress enacted the American Inventors Protection Act of 1999 (“AIPA”), a law that fundamentally changed much of the patent application process, by forcing applications filed in the United States to be disclosed after 18 months, rather than when the patent was granted.²⁶

The law as it stands today allows a utility patent grant to be effective for a term beginning on the earliest date the application was filed and ends 20 years later.²⁷ Although, the patent term may be extended in certain instances, a patent holder can only charge royalties for use of his or her invention during this timeframe, but not after the period expires.²⁸ For applications filed before June 8, 1995, the former patent term of 17 years from the date of issuance, or 20 years from the earliest filing date, remains effective, whichever is longer.²⁹ Although federal courts have exclusive jurisdiction over actions arising under patent laws, actions to enforce license agreements are enforced by general common law of contracts.³⁰ Nevertheless, federal

invention).

²⁵ See Eric P. Vandenburg, *Article: America Invents Act: How it Affects Small Businesses*, 50 Idaho L. Rev. 201, 202 (2014) (underscoring that under the new system, the person who was fastest in writing and submitting a patent application to the USPTO gets the patent rights).

²⁶ See American Inventors Protection Act, ch. 106-13, 113 Stat. 1501 (1999) (pointing to the federal act enacted by Congress in order to address newer and efficient systems to protect inventor’s rights).

²⁷ See 35 U.S.C. § 154(a)(2) (2016) (describing 20-year pre-expiration period for patents).

²⁸ See 35 U.S.C. § 154 (2016) (referencing certain extenuating instances when patent term may be extended such as delays caused by USPTO or regulatory authorities); 35 U.S.C. § 154(a)(2) (emphasizing that patentees may not receive post-expiratory royalties).

²⁹ See McJOHN, *supra* note 23, at 321 (noting the 20-year rule does not apply to patents filed before June 8, 1995 effective date).

³⁰ See 28 U.S.C. § 1338(a) (noting that Patent Act remains federal subject-matter); *Beraha v. Baxter Health Care Corp.*, 956 F.2d 1436, 1442 (7th Cir. 1992) (distinguishing that disputes arising from licensing agreements fall under category of

patent licensing policy preempts state contract law.³¹

C. The Ongoing Tension Between Patent Law and Antitrust Law

Since the late 19th and early 20th century, courts have been trying to resolve the pressing tension between antitrust law and patent law.³² This discordance is not surprising, given that patent law encourages monopoly while antitrust law opposes it.³³ In particular, courts have often interpreted the grant of a patent as a grant of “statutory monopoly.”³⁴ But, when the patent expires, the monopoly created by it expires too, and the subject matter of the invention passes to the public.³⁵ Thus, the patent system was created to promote invention while at the same time preserve competition.³⁶

Alternately, the principal objective of antitrust policy is to maximize consumer welfare by encouraging firms to behave competitively.³⁷ At the same time, antitrust law is focused on the misallocation of resources due to monopoly power, primarily caused by anti-competitive conduct that allows market participants to restrict competition and decrease output.³⁸ As a result, Congress passed the

common law of contracts).

³¹ See *Beraha*, 956 F.2d at 1442 (demonstrating that when licensing agreements run against policies supporting either patent or antitrust legislation—local contract law is usual standard for determining validity of license agreements and must yield to a developing body of federal law restricting scope of acceptable conditions).

³² See Robin Feldman, *Patent and Antitrust: Differing Shades of Meaning*, 13 VA. J.L. & TECH. 5, 1 (2008), archived at perma.cc/TD4Z-4TCB (reducing inherent challenges brought forth by both bodies of law as contradictory because patent law encourages monopoly, while antitrust law restricts it).

³³ See *id.* (bifurcating prevalent tension between patent and antitrust policy).

³⁴ See *Sears v. Stiffel Co.*, 376 U.S. at 229 (1964) (delineating the strain between patent law and antitrust law has been at the forefront of federal jurisprudence for more than a century).

³⁵ See *id.* at 230 (emphasizing that the patentees may not receive post-expiratory royalties).

³⁶ See *id.* at 229-30 (explaining that the general aim of patent law is to foster innovation, while creating opportunities for unrestrained competition).

³⁷ See PHILLIP E. AREEDA & HERBERT HOVENKAMP, *ANTITRUST LAW: AN ANALYSIS OF ANTITRUST PRINCIPLES AND THEIR APPLICATION* 100 (4th ed. 2013) (underpinning that antitrust policy promotes fair competition).

³⁸ See *Leegin Creative Leather Prods. Inc. v. PSKS, Inc.*, 551 U.S. 877, 886 (2007) (explaining that antitrust law regulates individuals or other such market forces that

Sherman Act to prevent or suppress devices or practices that create monopolies, or restrain trade or commerce, by suppressing or restricting competition, and obstructing the course of trade.³⁹ Even so, the application of the Sherman Act is fact-specific since it does not go into detailed definitions and makes only broad prohibitions.⁴⁰

Section 1 of the Sherman Act is the relevant provision that applies to patent royalty arrangements because it prohibits agreements that unreasonably restrain trade.⁴¹ The rule of reason is the prevailing standard of antitrust analysis, and courts apply it to agreements challenged by § 1.⁴² This rule often requires an extensive and copious case-by-case inquiry to determine whether the agreement is one that merely regulates or promotes competition or

stifle competition).

³⁹ See 15 U.S.C. § 1 (2016) (setting forth the Sherman Antitrust Act, proscribed by Congress in order to stimulate and enforce free and fair competition); 54A AM. JUR. 2d *Monopolies, Restraints of Trade, and Unfair Trade Practices* § 1 (2009) (highlighting the central purpose of the Sherman Antitrust Act was to promote fair competition, and oppose the combination of entities that could potentially harm it, such as monopolies or cartels); see also Monique M. Sadarangani, *Patent Tying and Antitrust Regulation—Moving Forward After Illinois Tool*, 13 J. HIGH TECH L. 613, 614 (2013) (emphasizing Congress's legislative purpose behind antitrust legislation). "Congress's primary focus through its legislation was stopping cartel-like behavior and monopolization." *Id.*

⁴⁰ See 54A AM. JUR. 2D *Monopolies, Restraints of Trade, and Unfair Trade Practices* § 7 (2016) (noting Sherman Act is broad in scope and contemplates conduct which unfairly tends to destroy competition itself).

⁴¹ See Kenneth G. Starling, *Increasing the FTC'S Burden: Quick Look Versus Full Rule of Reason*, FEDERALIST SOC'Y (Aug. 1999), archived at <https://perma.cc/YE8D-FW8E> (clarifying Sherman Act was proscribed to apply only to those agreements unreasonably encumber trade).

⁴² See *Leegin*, 551 U.S. at 877 (explaining that "[t]he rule of reason is the accepted standard for testing whether a practice restrains trade in violation of § 1."); see also *Texaco Inc. v. Dagher*, 547 U.S. 1, 5 (2006) (stating that courts still apply rule of reason, particularly in instances where a restraint on trade is not ancillary to main purpose of an agreement). "[T]his court presumptively applies rule of reason analysis." *Id.* See also *Business Electronics Corp. v. Sharp Electronics Corp.*, 485 U.S. 717, 717 (1988) (explaining that determining whether a particular agreement violates § 1 is ordinarily assessed through a case-by-case application of rule of reason); *Northwest Wholesale Stationers, Inc. v. Pacific Stationery and Printing Co.*, 472 U.S. 284, 289 (1985) (noting rule of reason analysis guides inquiry); *Continental T.V., Inc. v. GTE Sylvania Inc.*, 433 U.S. 36, 49 (1977) (adding rule of reason is prevailing standard). "[The] per se rules of illegality are appropriate only when they relate to conduct that is manifestly anticompetitive." *Continental T.V., Inc.*, 433 U.S. at 49-50.

perhaps unreasonably suppresses it.⁴³ Further, all competitive effects of a restraint—including the anticompetitive effects—along with any potential pro-competitive effects—are balanced to determine whether the net effect of the arrangement is unreasonably anti-competitive.⁴⁴

D. *The Brulotte Legacy*

For economic or technological reasons, a patentee may decide his or her patent can be exploited most advantageously by licensing others to make, use or sell the invention.⁴⁵ However, since this right is statutorily limited, a patentee entering into a license agreement providing for royalty payments, which extend beyond the expiration date of the patent may be guilty of patent misuse.⁴⁶ The seminal case on the issue of royalties collected on expired patents remains *Brulotte v. Thys Co.*, 379 U.S. 29 (1964).⁴⁷

Brulotte arose over the sales of hop-picking machines that

⁴³ See *Leegin*, 551 U.S. at 886 (emphasizing rule of reason is centered on total effect of a particular restraint).

⁴⁴ See *Leegin*, 551 U.S. at 877 (describing copious economic balancing test required by rule of reason); see e.g., *Bus. Elecs. Corp.*, 485 U.S. at 732 (explaining an application of rule of reason calls for a circumstantial inquiry). “[T]he factfinder weighs all of the circumstances of a case in deciding whether a restrictive practice should be prohibited as imposing an unreasonable restraint on competition.” *Id.* at 723 (citing *Continental T.V., Inc.*, 433 U.S. at 36); see also *Bd. of Trade of City of Chicago v. U.S.*, 246 U.S. 231, 238 (1918) (noting rule of reason requires a complete and thorough assessment of particular facts-at-bar).

⁴⁵ See Larry R. Fisher, *The Misuse Doctrine and -Discriminatory-and Exorbitant Patent Royalties*, 43 IND. L.J. 106, 107 (1967) (noting there could be financial or technological motives for licensing a patent); Christopher A. Cotropia, “*After-Arising*” *Technologies and Tailoring Patent Scope*, 61 N.Y.U. ANN. SURV. AM. L. 151, 170 (2005) (allowing patentees an opportunity to invent and have exclusive control over their invention); Mark A. Lemley, *Colloquium: Ex Ante versus Ex Post Justifications for Intellectual Property*, 71 U. CHI. L. REV. 129, 129-30 (2004) (protecting inventors investment in their ideas); see also Maayan Perel, *An Ex Ante Theory of Patent Valuation Transforming Patent Policy to Patent Value*, 14 J. HIGH TECH. L. 148, 152 (2014) (noting that patentee’s right to negotiate licenses are generally uninhibited by the U.S. patent system).

⁴⁶ See *Fisher*, *supra* note 45, at 107 (emphasizing such acts occur when a patent holder’s use of a patent to restrain trade beyond enforcing the exclusive rights that a lawfully obtained patent provides).

⁴⁷ See *Brulotte*, 379 U.S. at 29 (explaining the facts of *Brulotte*; the prevalent case in the area of patent misuse).

were covered by seven patents.⁴⁸ The terms of the sales included a flat sum purchase price, as well as an ongoing license requiring additional annual royalty payments based on use.⁴⁹ The duration of the license extended beyond the date by which all seven patents expired.⁵⁰ The license also included restrictions on assignments and relocation of the machines, both before and after the expiration of the patents.⁵¹ In addition, the annual royalty payment calculations were the same for the expiration period as they were for the period of the patent.⁵²

Although the lower court found that the license's extension into the post-expiration period reflected only "a reasonable amount of time over which to spread the payments for use of the patent," the Supreme Court disagreed.⁵³ In doing so, the Court noted that the "royalty payments due for their post-expiration period are, by their terms, for use during that period, and are not deferred payments for use during the pre-expiration period."⁵⁴ The Court explained that the license terms were "apt and pertinent to the protection of the patent monopoly, and their applicability to the post-expiration period is a telltale sign that the licensor was using the licenses to protect its monopoly beyond the patent period."⁵⁵ The Court then concluded that, "[i]n light of those considerations . . . a patentee's use of a royalty agreement that projects beyond the expiration date of the patent is unlawful *per se*."⁵⁶ Thus, *Brulotte* implemented the *per se* rule to

⁴⁸ See *id.* at 30 (describing the patents obtained for the purpose of hop growing and harvesting equipment).

⁴⁹ See *id.* at 29 (explaining the terms of the royalty arrangement in the precedent case).

⁵⁰ See *id.* at 30 (highlighting that the terms of the licensing agreement exceeded beyond the statutory period for patents).

⁵¹ See *id.* at 32 (indicating additional arrangements that were tied into the royalty agreement).

⁵² See *id.* at 31 (emphasizing that the royalty calculations were the same before and after the expiratory period).

⁵³ See *Brulotte*, 379 U.S. at 30 (positing that the Supreme Court took the opposite stance from the lower court who had sided with the petitioner, Kimble).

⁵⁴ See *id.* at 31 (explaining the Supreme Court's landmark holding that royalty agreements cannot be enforced pursuant to the expiratory period).

⁵⁵ See *id.* at 32 (highlighting that patents provide limited monopolies—not meant to exceed the post-expiratory period).

⁵⁶ See *id.* (creating a bright-line rule that royalty agreements that exceed beyond the statutory period is on its face, unlawful).

protect the public against abuse of the patent system—particularly against misuse related to impermissible extensions of the duration of a patent’s limited statutory monopoly.⁵⁷

E. *Brulotte* Criticism

Predictions were made that the *Brulotte* decision would be of little significance and apply only to a similar factual situation.⁵⁸ Despite these forecasts, today, over five decades later, *Brulotte* remains good law.⁵⁹ But, the decision has been widely criticized by scholars and legal theorists arguing that the case be overruled.⁶⁰ One concern was that *Brulotte* allows the federal court’s to interfere between private contracts.⁶¹ Other commentators have pointed out that “post-expiration royalties merely amortize the price of using patented technology” and therefore do not represent an extension in time of the patented monopoly.”⁶² Economists have called the *Brulotte* bright-

⁵⁷ See *id.* at 33 (describing the Court’s ruling that a patent empowers the owner to exact royalties). The owner is entitled to royalties as high as he can negotiate with the leverage of that monopoly. *Id.* However, to use that leverage to project those royalty payments beyond the life of the patent is analogous to an effort to enlarge the monopoly of the patent by tying the sale or use of the patented article to the purchase or use of unpatented ones. *Id.*

⁵⁸ See George E. Frost, *The Supreme Court and Patent Abuse*, 29 A.B.A. SEC. ANTITRUST L. 122, 129-30 (1965) (noting earlier skepticism within the legal community that *Brulotte* would not have lasting effect).

⁵⁹ See Michael Koenig, *Patent Royalties Extending Beyond Expiration: An Illogical Ban From Brulotte to Scheiber*, 2003 DUKE L. & TECH. REV. 5 (2003) (expressing that decades later *Brulotte* stands as good law).

⁶⁰ See *Scheiber v. Dolby Labs Inc.*, 293 F.3d 1014, 1017-1018 (7th Cir. 2002) (stating that “[*Brulotte*] has . . . been severely . . . with all due respect justly criticized . . . [h]owever, we have no authority to overrule a Supreme Court decision no matter how dubious its reasoning strikes us, or even how out of touch with the Supreme Court’s current thinking the decision seems”).

⁶¹ See Paul Goldstein, *Federal System Ordering of the Copyright Interest*, 69 COLUM. L. REV. 49, 70 (1969) (noting the argument that *Brulotte* clashes with parties’ right to contract with one another). “In the presence of only the most attenuated federal interest and absent any generalized public concern, the *Brulotte* rule gives to the federal courts a broad and probably illegitimate supervisory power over state administration private contracts.” *Id.*

⁶² See Harold See & Frank M. Caprio, *The Trouble with Brulotte: The Patent Royalty Term and Patent Monopoly Extension*, 1990 UTAH L. REV. 813, 814, 819, 851 (1990) (citing that “[t]he *Brulotte* rule incorrectly assumes that a patent license has significance after the patent terminates”); see also Richard Gilbert & Carl Shapiro,

line rule “flawed” and contend that “allocative efficiency considerations should permit a licensor and licensee to agree to royalty terms.”⁶³ Contrary to the reasoning in *Brulotte*, U.S. antitrust enforcement agencies have noted that it is “possible that collecting royalties over a longer period of time than the patent grant will reduce the deadweight loss associated with a patent monopoly and allow the patent holder to recover the full value of the patent, thereby preserving innovation incentives.”⁶⁴ In his dissenting opinion, Associate Justice John Harlan II believed that the majority failed to understand the “substantive economic effect” of the provisions.⁶⁵ The Seventh Circuit has questioned whether obtaining post-expiration royalties “really ‘extends’ the patent,” and noted that *Brulotte* has been “severely . . . and justly, criticized.”⁶⁶ The Circuit Court reasoned that “paying royalties after the patent expires does not extend the duration of the patent either technically or practically, because. . . if the licensee agrees to continue paying royalties after the patent expires the royalty rate will be lower.”⁶⁷ Such licenses are therefore nothing more than “a risk-shifting credit arrangement between patentee and licensee.”⁶⁸

Antitrust Issues in the Licensing of Intellectual Property: The Nine No-No's Meet the Nineties, BROOKINGS PAPERS: MICROECONOMICS 320 (1997), archived at <https://perma.cc/BX2K-NYEA> (framing the argument made by commentators that extending a patent term beyond the statutory limit has the effect of amortization; therefore it should not be categorized as patent misuse).

⁶³ See Gilbert & Shapiro, *supra* note 62, at 322 (contending that if the licensing agreement calls for royalty payments beyond the patent term, the parties base those payments on the licensee’s assessment of the value of the license during the patent period; therefore, the *Brulotte* rule is based on a faulty premise).

⁶⁴ See U.S. DEP’T OF JUST. & FED. TRADE COMM’N, ANTITRUST ENFORCEMENT AND INTELLECTUAL PROPERTY RIGHTS: PROMOTING INNOVATION AND COMPETITION 122 (2007) (explaining that allowing collection of royalties over an extended period would help recover allocated inefficiency inherently present in patent monopolies).

⁶⁵ See *Brulotte*, 379 U.S. at 37 (highlighting that extending the patent term for collecting royalty payments may lead to more innovation).

⁶⁶ See *USM Corp. v. SPS Techs. Inc.*, 694 F.2d 505, 510 (7th Cir. 1982) (noting the majority casted doubt on the holding in *Brulotte*); *Scheiber v. Dolby Labs., Inc.*, 293 F.3d 1014, 1017 (7th Cir. 2002) (describing the way courts have treated the *Brulotte* opinion).

⁶⁷ See *Scheiber*, 293 F.3d at 1017 (framing a counterargument against the prohibition of collecting patent royalties beyond the term limit because doing so would not directly nor indirectly effect the patent term limit).

⁶⁸ See *id.* (pronouncing that allowing parties to structure agreements beyond the pa-

III. Premise

A. Still Haunted by *The Ghost Of Brulotte*.

In *Kimble v. Marvel Entertainment, LLC.*,⁶⁹ Stephen Kimble (hereinafter, “Kimble”) invented and patented a toy (“Web Blaster”) that allows a person to shoot foam string from the palm of one’s hand, similar to the Marvel superhero Spider-Man.⁷⁰

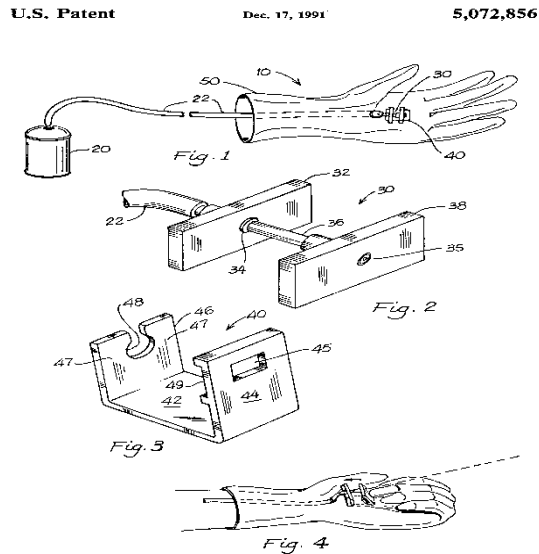

As part of a settlement of litigation with Marvel Enterprises,

tent term would function merely as a risk-shifting credit agreement).

⁶⁹ See *Kimble*, 135 S. Ct. at 2405 (referring to the toy that Kimble invented which allows a child to role play as Spider Man by mimicking its web shooting abilities with foam string).

⁷⁰ See U.S. Patent No. 5,072,856 (filed Dec. 19, 1991) (displaying how the invention functions).

Inc., Kimble assigned the patent to Marvel in exchange for a 3% royalty on future net product sales of the Web Blaster.⁷¹ The settlement agreement, however, did not specify when termination of the royalty payments would end, and over the years Marvel paid more than \$6 million to Kimble.⁷² Moreover, the parties admitted that when they signed the agreement, they did not know about the *Brulotte* prohibition on post-expiratory royalties.⁷³ Nevertheless, a dispute arose in connection with Marvel's royalty obligations and Kimble sued for breach of the settlement agreement.⁷⁴ Marvel counterclaimed for a declaratory judgment arguing that their royalty obligations ended with the expiration of the patent—and any obligations to pay royalties after that date was unenforceable under *Brulotte*.⁷⁵ The Ninth Circuit reluctantly agreed and granted Summary judgment to Marvel.⁷⁶ Subsequently, Kimble was granted certiorari in the United States Supreme Court on the question of whether the Court should overrule *Brulotte* in favor of a more flexible case-by-case analysis under the antitrust “rule of reason.”⁷⁷ In a 6-3 decision, the Supreme

⁷¹ See *Kimble*, 135 S. Ct. at 2406 (noting that Kimble assigned their patent to Marvel, in return for a lump-sum payment and an additional running royalty of 3% of total product sales).

⁷² See *Kimble v. Marvel Enterprises Inc.*, 727 F.3d 856, 857 (9th Cir. 2013), *aff'd*, 135 S. Ct. 2401 (2015); see also Brief for Kimble et al. v. Marvel Entertainment, Inc. as Amici Curiae Supporting Petitioners, *Kimble v. Marvel Enterprise, Inc.*, 135 S. Ct. 2401 (2015) (No. 13-720), 2015 WL 510928 (pointing out that Kimble received scheduled royalty payments during the pre-expiration period of the patent).

⁷³ See *Kimble*, 135 S. Ct. at 2406 (“Marvel stumbled across *Brulotte*, the case at the heart of this dispute”).

⁷⁴ See *Kimble* 727 F.3d at 859 (referring to the claim that Marvel failed to pay royalties). “These disputes revolved around the calculation of royalties for subsequent iterations of the Web Blaster that included additional functions (in addition to shooting foam string) or Web Blasters that were packaged with other role play items (such as Spider-Man masks).” *Id.*

⁷⁵ See *id.* (citing that a declaratory judgment was issued in federal district court confirming that it could stop paying Kimble royalties).

⁷⁶ See *Kimble*, 135 S. Ct. at 2406 (referring to J. Kagan’s consensus that the Ninth Circuit was not too happy about issuing summary judgment for Marvel); see also *Kimble*, 727 F.3d at 877 (describing J. Callahan’s Ninth Circuit’s opinion and the court’s disinclination in ordering Summary judgment against the petitioners). “We acknowledge our application of the *Brulotte* rule in this case arguably deprives Kimble of part of the benefit of his bargain based upon a technical detail that both parties regarded as insignificant at the time of the agreement.” *Kimble*, 135 S. Ct. at 2406.

⁷⁷ See *Kimble*, 135 S. Ct. at 2407-08 (noting that *Kimble* wanted to overrule

Court, led by Justice Elena Kagan, affirmed the Ninth Circuit's decision, and dismissed the case on the basis of *stare decisis*.⁷⁸

B. Patent Policy

The eighteen-page opinion began with the general rule that “patents endow their holders with certain superpowers, but only for a limited time . . . and when the patent expires, the patentee’s prerogatives expire too, [along] [with] the right to make or use the article, free from all restrictions passes to the public.”⁷⁹ The Court emphasized that “[i]n crafting the patent laws, Congress struck a balance between fostering innovation and ensuring public access to discoveries”; therefore they have “carefully guarded the cutoff date.”⁸⁰ In congruence with *Brulotte*, Justice Kagan explained, “contracts to pay royalties for such use [after the patent term expires] continues the ‘patent monopoly’ beyond the [patent] period.”⁸¹ Thus, this “conflict[s] with patent law policy of establishing a post-expiration . . . public domain” in which every person can make free use of a formerly patented product.⁸²

C. Respecting *Stare Decisis* Means Sticking To Some Wrong Decisions⁸³

The Court decided not to apply a rule of reason analysis on the basis of *stare decisis*.⁸⁴ The Court underscored that *stare decisis*

Brulotte on the basis of antitrust analysis and law).

⁷⁸ See *id.* at 2405-06, 2415 (indicating that the Court was not willing to overturn the Ninth Circuit’s decision).

⁷⁹ See *id.* at 2406-07 (highlighting the term limit applied to patents).

⁸⁰ See *id.* at 2407 (noting that they have carefully guarded the cutoff date in cases involving State statutes that restrict the cutoff date and private contract provisions limiting the free use of such inventions).

⁸¹ See *id.* at 2407 (tying the opinion in *Brulotte* that patents that extend to the post-expiration period is a telltale sign that the licensor was using the licenses to project a monopoly beyond the patent period).

⁸² See *id.* at 2407-08 (explaining the public policy to have the opportunity to freely use or make a patented product).

⁸³ See *Kimble*, 135 S. Ct. at 2409 (quoting former Supreme Court Justice Brandeis who famously wrote, that it is usually “more important that the applicable rule of law be settled than that it be settled right”).

⁸⁴ See *id.* at 2410 (citing *Michigan v. Bay Mills Indian Cmty.*, 134 S. Ct. 2024,

promotes stability and continuity in the law.⁸⁵ Yet, the opinion distinguished that *stare decisis* has lesser force on antitrust cases because of the amorphous and variable economic dynamics presented in such cases.⁸⁶ Notwithstanding this distinction, the majority established that *Kimble* is a patent rather than an antitrust case.⁸⁷ Therefore, the Court openly acknowledged that showing judicial reverence for legal precedent might mean standing beside some bad decisions.⁸⁸

In particular, the ruling emphasized that *stare decisis* carries stronger weight when a decision interprets a statute because congressional statutory interpretations are considered to have strict presumptions of correctness.⁸⁹ As a result, the *Kimble* Court deferred any mistakes to the legislature.⁹⁰ Even more, the Court noted that Con-

2036 (2014) (referring to *stare decisis* as “the foundation stone of the rule of law”); see also *Kimble*, 135 S. Ct. at 2418 (using a web of puns on behalf of the majority, J. Kagan weaves into the opinion, a famous quote from the Spiderman comic book, to encapsulate the Court’s firm stance on only sparingly overturning well-established precedent. “[I]n this world, with great power there must also come—great responsibility.” S. Lee and S. Ditko, *Amazing Fantasy No. 15: “Spider-Man,”* p. 13 (1962).

⁸⁵ See *Kimble*, 135 S. Ct. at 2417-18 (emphasizing that the Court would not apply an antitrust analysis to the facts because the case stemmed from a patent dispute). The Court explained that it, “promotes the evenhanded, predictable and consistent development of legal principles, fosters reliance on judicial decisions and contributes to the actual and perceived integrity of the judicial process.” *Id.*

⁸⁶ See *id.* at 2418 (bifurcating patent from antitrust precedents in that the latter may be overruled).

⁸⁷ See *id.* at 2411, 2418 (expressing the majority’s decision to not undue “stable” law and overriding the argument that the court should apply an antitrust analysis and overrule *Brulotte*).

⁸⁸ See Neil J. Wilkof et al., *Kimble v Marvel Entertainment: when post-expiry patent royalties meet stare decisis*, IPKAT (July 27, 2015), archived at <https://perma.cc/KVE5-Y46P> (stressing that overriding precedent requires a justification that is over and above a good reason).

⁸⁹ See *Kimble*, 135 S. Ct. at 2412 (highlighting the higher level of scrutiny that must be applied in abrogating congressionally promulgated laws in decisions like *Brulotte* that interpret a statute). “[O]verturning decisions that interpret a statute carr[y] enhanced force.” *Id.*

⁹⁰ See *id.* at 2409 (highlighting the Court’s opinion that Congress’ failure to overturn *Brulotte* serves as proof of their unwillingness to do so. The Court is also emphasizing the importance of separation of powers between the judicial and legislative branch). “[O]nly Congress can correct any mistake it sees [fit].” *Id.*

gress had been given several opportunities to overturn *Brulotte*—but seemingly supports still leaving it in place.⁹¹ Therefore, there needed to be a “superspecial justification to warrant reversing *Brulotte*.”⁹² In addition, the Court recognized that to date, the core features of the patent laws, which *Brulotte* relied upon still remain prevalent.⁹³ The Court found evidence of this because modern patent decisions continue to aggressively police the boundaries of the patent scope—rejecting even private contract provisions which threaten to extend patent benefits beyond statutory limits.⁹⁴ Thus, the majority held that when a statute poses serious and harmful consequences for innovation—it should be addressed by Congress.⁹⁵

D. Pros of Extending Royalty Payments Beyond the Patent Term

The *Kimble* Court candidly acknowledged that *Brulotte* inhibits some parties from entering into deals that they want.⁹⁶ Three potential instances were cited when royalty payments extending beyond the patent term may lead to desirable results for the contracting parties.⁹⁷ The Court first noted, “as compared to lump sum fees, royalty plans both draw out payments over time and tie those payments, in each month or year covered, to a product’s commercial success.”⁹⁸ The Court next accredited that “a more extended pay-

⁹¹ See *id.* (providing further proof that the legislature has deliberately decided not to repeal the statute).

⁹² See *id.* at 2410 (emphasizing that there must be an exceptional justification to overturn *Brulotte* because it was based on a statute).

⁹³ See *Kimble*, 135 S. Ct. at 2410 (citing that *Brulotte* is not outdated). “*Brulotte*’s statutory and doctrinal underpinnings have not eroded overtime.” *Id.*

⁹⁴ See *id.* (explaining that modern patent decisions continue to guard against raising the term limit in virtually every way).

⁹⁵ See *id.* at 2414 (reframing the point that Congress is the proper audience to address the issue presented by *Kimble* in *Kimble*).

⁹⁶ See *id.* at 2415 (acknowledging that *Brulotte* may have been a poorly decided case).

⁹⁷ See *id.* at 2408 (delineating the potential benefits to overruling *Brulotte*).

⁹⁸ See *Kimble*, 135 S. Ct. at 2408 (highlighting in brief, the distinction between lump sum fees and royalty payments); see also Basam Nabulsi & Erik Paul Belt, *The Patent is Dead; Long Live The Royalties!*, IN VIVO: BUS. & MED. REP., May 2015, at 2 archived at <https://perma.cc/85H6-3SHC> (highlighting a study that estimated that academic licensing alone, including technology developed at universities, hospitals, and research institutes contributed from \$86 billion to \$338 billion

ment period, coupled . . . with a lower rate, may bring the price the patent holder seeks within the range of a cash-strapped licensee.”⁹⁹ As a final reason, Justice Kagan emphasized that royalty payments beyond the patent term may lead to a more effective “allocat[ion] of risk and rewards associated with commercializing inventions—most notably when years of development work stand between licensing a patent and bringing a product to market.”¹⁰⁰ Despite these acknowledgements, the Court cited *Brulotte* as posing an obstacle to administering post-expiratory patent royalty payments.¹⁰¹

E. Four Ways Around *Brulotte*

The *Kimble* Court sketched four ways that parties should be afforded broad leeway to draft royalty agreements without violating the *Brulotte* precedent.¹⁰² The Court recognized that *Brulotte* poses no bar to (1) amortization agreements—where parties set a royalty based on sales during the patent term, but remunerating it over a longer period extending passed the end of the patent term.¹⁰³ The

to this country’s gross domestic product over a 15-year period).

⁹⁹ See *Kimble*, 135 S. Ct. at 2408; see also Nabulsi & Belt, *supra* note 100, at 2 (presenting an advantage of extended royalty payments for licensees with limited upfront financial resources). Further indicating that nearly half of the biotech industry was founded on the basis of obtaining a license to technology. *Id.* Therefore, companies would favor increased flexibility in structuring licensing terms to more effectively share risk and address cash flow and capitalization issues. *Id.*

¹⁰⁰ See *Kimble*, 135 S. Ct. at 2408 (citing an instance when extending the patent term may lead to better allocation of risk and incentives to both licensees and patent holders).

¹⁰¹ See *id.* (pointing to the fact that overruling precedent based on statutory interpretation is not for the courts to decide unless there is an exceptional justification to do so).

¹⁰² See *id.* at 2413 (indicating that although the court cannot justify overruling *Brulotte*, there are ways parties can structure their agreements that will help them achieve similar results).

¹⁰³ See *id.* at 2408 (explaining that such amortization agreements help cash strapped licensees in the short-term and allocating risk in the long-term).

A licensee could agree, for example, to pay the licensor a sum equal to 10% of sales during the 20-year patent term, but to amortize that amount over 40 years. That arrangement would at least bring down early outlays, even if it would not do everything the parties might want to allocate risk over a long timeframe.

Court also expressed that the decision does not bar (2) multiple patents—where a large family of patents are licensed because royalties may run for all patents in the portfolio until the expiration of the last patent expires.¹⁰⁴ Additionally, the ruling poses no bar to (3) hybrid agreements—which include both the right to use the patent as well as trade secrets, or when the licensor provides technical support, or some other source of value to the licensee throughout the term of the license which may extend beyond the term of the patent.¹⁰⁵ As a final workaround, the Court explained that (4) business arrangements,

Id.

See also Nabulsi & Belt, *supra* note 98, at 5 (indicating that generally these licenses have required different royalty rates or payment structures for the period after the patent expires, in order to show that the royalties are not compensating for some aspect of the bargain).

¹⁰⁴ See *Kimble*, 135 S. Ct. at 2408 (citing a second way to get around *Brulotte*, by extending royalties until the last-to-expire of a patent portfolio). “[W]hen a licensing agreement covers either multiple patents or additional non-patent rights, royalties may run until the latest-running patent covered in the parties’ agreement.” *Id.* See also Dennis Crouch, *Guest Post: A Small Practice Note on Patent Family Licensing with a Billion Dollar Effect?*, PATENTLYO (Oct. 18, 2015), archived at <https://perma.cc/6Z58-2C3S> (explaining that “licensed patents” are thus normally expressly defined to be “anything related” to the original patents); David Long, *Supreme Court still prohibits patent royalties for activity occurring after patent expires (Kimble v. Marvel)*, ESSENTIAL PAT. BLOG (June 22, 2015), archived at <https://perma.cc/9XVC-XB74> (explaining that the license may also grant rights to other kinds of intellectual property that continue long passed the expiration of the patent).

¹⁰⁵ See Long, *supra* note 104 (permitting licensing non-patent rights—such as “know-how” or trade secrets no matter how closely tied to the patent). “Post-expiration royalties are allowable so long as tied to a non-patent right—even when closely related to a patent.” *Id.* See also William D. Hall, *Regular Audits of technology license agreements may reduce your patent royalty payments*, JD SUPRA BUS. ADVISOR (2016), archived at <https://perma.cc/LNQ2-AMER> (noting that business arrangements are a legally acceptable workaround to *Brulotte*).

Under these conditions, compliance with the requirements established by the Supreme Court warrants a two-tier royalty schedule. The two-tier royalty schedule recognizes the diminution in value in the license following the expiration of the last licensed patent. Thus, following expiration of the last license patent, the second-tier royalty obligation will be less than the first tier.

Id.

other than royalty agreements to commercialize an invention are legally permissible.¹⁰⁶ Furthermore, the opinion signaled that *Kimble's* impact on real word licenses—and licenses currently being negotiated—can be circumvented by careful drafting, but the extent of its reach will almost certainly depend on its further application and interpretation by the lower federal courts.¹⁰⁷

IV. Analysis

The preceding sections provided an introduction to the Supreme Court's posture in guarding the twenty-year expiration date of patents; allowing the public the unrestricted right to make or use a

¹⁰⁶ See *Kimble*, 135 S. Ct. at 2408 (indicating that *Brulotte* poses no bar to business arrangements other than royalties). In particular, the majority pronounced “*Brulotte* poses no bar to business arrangements other than royalties—all kinds of joint ventures, for example—that enable parties to share the risks and rewards of commercializing an invention”. *Id.* See also Lovenworth & Dolak, *supra* note 8 (explaining that “[o]ne such arrangement might be where the license agreement may provide for milestone payments triggered by developments related to the commercialization of the patent (e.g., FDA approval)”). Additionally, these development milestones may occur after the expiration of the patent, thereby allowing the patent owner to collect money from the licensing agreement even post-expiration.” *Id.* See also Nabulsi & Belt, *supra* note 98 (discussing an example of a business arrangement that does not violate *Brulotte*). Providing as an example that “a license agreement for a pharmaceutical compound could tie a lump-sum payment to FDA approval. *Id.* These types of provisions can allow licensors and licensees to align their interests and tie the benefits and burdens of a license agreement to real-world commercial events.” *Id.*

¹⁰⁷ See Hall, *supra* note 105 (emphasizing the importance of conducting audits to licensing agreements.) Additionally, enumerating that:

A license agreement audit should begin by identifying all current royalty payments and associating the payments with the appropriate license agreement. Following this step, several sections of each license agreement should be reviewed. These include: (1) Term and Termination, (2) License Grant, (3) Confidentiality, (4) Royalty Payments, (5) Schedule of Patents licensed, and (6) Schedule of Technology licensed. Each of these sections may identify a basis for terminating royalty payments.

Id.

patented article after that date.¹⁰⁸ The following subsections analyze creative ways patent licensors can structure royalty arrangements, beyond the statutory term-limit— without impinging on the bright-line *Brulotte* rule.

A. *Effect on Competition of Extending Royalties Beyond The Term Limit*

Kimble noted that royalty plans draw out payments over time and tie those payments, in each month or year covered, to a product's commercial success.¹⁰⁹ In doing so, the Court acknowledged that post-expiration royalties can be pro-competitive and that *Brulotte* may have perhaps relied on an economic error of judgment.¹¹⁰ At first blush, this appears to conflict with the *Brulotte* Court's stance that the applicability of license terms to the post-expiration period is a telltale sign that the licensor was acting anticompetitively by protecting its monopoly beyond the patent period.¹¹¹ However, the *Kimble* Court distinguished that *Brulotte* was a patent case—and not an antitrust case; therefore the rule of reason was not the appropriate standard of review.¹¹² Still, the majority acknowledged that *Kimble* may have perhaps raised a valid and meritorious claim because *Brulotte* applied a standard of review that was too rigid and outdated, notwithstanding the economic realities of modern patent law.¹¹³ As such, this seems to indicate two noteworthy underlying points: (1) post-expiration royalties could have pro-competitive effects; (2) and that the Supreme Court is open to analyzing future patent law cases

¹⁰⁸ See 35 U.S.C. § 154 (a)(2) (referencing the 20-year term limit for patents).

¹⁰⁹ See *Kimble*, 135 S. Ct. at 2416 (highlighting in brief, distinction between lump sum fees and royalty payments). “There are, however, good reasons why parties sometimes prefer post-expiration royalties over upfront fees, and why such arrangements have pro-competitive effects.” *Id.*

¹¹⁰ See *id.* at 2404 (admitting that *Kimble* made no error in their economic analysis).

¹¹¹ See *Brulotte*, 379 U.S. at 32 (highlighting that patents provide limited monopolies—not meant to exceed post-expiratory period).

¹¹² See *Koenig*, *supra* note 59, at 6 (explaining that patent—not antitrust policy—gave rise to Court's conclusion that post-patent royalty contracts are unenforceable—regardless of a demonstrable effect on competition).

¹¹³ See *Kimble*, 135 S. Ct. at 2405 (discussing that “*Kimble's* real complaint may go to the merits of such a patent policy”). What he describes as “formalis[m],” its “rigid[ity],” and its detachment from “economic reality.” *Id.* at 2414.

through an economic lens.¹¹⁴ Nevertheless, the *Kimble* Court concluded that Congress is the appropriate forum to address both issues.¹¹⁵

B. Benefits and Drawbacks of Extending Royalties Beyond The Term Limit

Kimble openly acknowledged potential benefits of post-expiration licensing agreements.¹¹⁶ The Court reasoned that extending the payment period with a lower rate may be beneficial to parties because it allows a great deal of flexibility in structuring deals, particularly for cash-strapped licensees.¹¹⁷ This appears most prevalent in today's market economy, particularly in the billion dollar biotech industry where patent licensing remains a critical component of many companies' business models.¹¹⁸ *Kimble* acknowledges that royalty payments beyond the patent term may lead to a more efficient and even-handed approach, especially when years of development work stand between licensing a patent and bringing a product to market.¹¹⁹ In these instances, enforcing patent royalty payments after its expiration appears reasonable.¹²⁰

In contrast, however, Marvel makes a poignant assertion in *Kimble*—that by overturning *Brulotte*'s bright-line rule—inventors could exploit their market power beyond the life of the patent, harming consumers along with innovators who create new products and

¹¹⁴ See *id.* at 2415 (acknowledging that perhaps *Brulotte* may have been decided on an economic misjudgment).

¹¹⁵ See *id.* at 2414 (determining that Congress is “proper audience” to make this determination).

¹¹⁶ See *id.* at 2416 (opining that extending royalty term has economic benefits because it allows parties to essentially spread licensing fees over a longer period of time, which results in a reduction of fees during patent term).

¹¹⁷ See *id.* at 2408 (describing how extending royalty payments beyond patent term offsets high upfront costs of royalty payments and offers more flexibility for payments over a longer period of time).

¹¹⁸ See *Nabulsi & Belt, supra* note 98 (presenting evidence that profits from recurring royalty payments are a significant portion of medtech industry's bottom line).

¹¹⁹ See *Kimble*, 135 S. Ct. at 2408 (citing an instance when extending patent term may lead to better allocation of risk and incentives to both licensees and patent holders).

¹²⁰ See *id.* (signaling that extending patent term may have certain benefits in certain circumstances).

technologies.¹²¹ Thus, the majority in *Kimble* seems to have struck a reasonable chord by deferring the decision to the legislature on the basis of *stare decisis*, particularly because the bright-line *Brulotte* rule has proven to be stable and reliable law.¹²² Therefore, while there are benefits to extending patent royalties beyond the term limit, the current system is not outdated enough to overturn *Brulotte* and sacrifice *stare decisis* principles.¹²³

C. Alternative Routes Around *Brulotte*

1. Amortization Arrangements

Kimble explicitly signals several alternative workarounds to *Brulotte*, that contracting parties may employ in their licensing agreements.¹²⁴ Parties can agree to pay the patent owner royalties based on sales during the patent term, but amortizing payments over a longer period extending passed the end of the patent.¹²⁵ In addition, if parties entering into a patent license agreement want to pick a number today for a license fee, they can amortize that over any period they choose.¹²⁶ The caveat, however, is that such agreements cannot make post-expiration payments depend on the post-expiration sales.¹²⁷ Doing so would be in violation of the bright-line rule reaf-

¹²¹ See *id.* at 2412 (contending that “during the patent term, those reduced rates may lead to lower consumer prices, making the patented technology more competitive with alternatives; too, the lesser rates may enable more companies to afford a license, fostering competition among the patent’s own users”).

¹²² See *id.* at 2411 (speaking for the majority, J. Kagan described court’s position on *Brulotte* holding). She categorized it as being “stable law.” *Id.*

¹²³ See *id.* at 2415 (conceding that Court implicitly expressed that *Brulotte* is not outdated). Speaking directly from the bench, J. Kagan openly acknowledged “*Brulotte* has governed licensing agreements for more than half a century.” *Id.* at 2410.

¹²⁴ See *Kimble*, 135 S. Ct. at 2408 (hinting that parties can find ways around bright-line rule, ultimately allowing them to achieve same desired aims as overturning precedent).

¹²⁵ See *id.* (providing some insight on how parties can legally structure amortization agreements).

¹²⁶ See *id.* (presenting as an example “[a] licensee could agree, for example, to pay the licensor a sum equal to 10% of sales during the 20-year patent term, but to amortize that amount over 40 years”).

¹²⁷ See Lovenworth & Dolak, *supra* note 8 (emphasizing that amortization payments must reflect only royalties incurred during statutory term period).

firmed in *Kimble*.¹²⁸ The advantage of amortization agreements is that they help parties that cannot afford to pay royalties early on, because of the high upfront costs of royalty payments.¹²⁹ Amortizing payments promotes business transactions by spreading risk and reward allocation over a predetermined extended period of time.¹³⁰ Ultimately, this can be seen as being pro-competitive and in harmony with patent law policy.¹³¹

2. Multi-patent Arrangements

Where a large portfolio of patents is licensed, royalties may run for all patents in the portfolio until the expiration of the last patent in the portfolio is set to expire.¹³² The license may also grant rights to other kinds of intellectual property, such as trademarks that continue long passed the expiration of the patent.¹³³ Any such license should distinguish those portions of the royalty that compensates for other rights and should reduce the royalty rate accordingly after the patent expires.¹³⁴ Such agreements are beneficial to parties because it allows them to enter into agreements that they desire without violating the bright-line *Brulotte* rule.¹³⁵

¹²⁸ See Lovenworth & Dolak, *supra* note 8 (clarifying that collecting licensing royalties for a period beyond patent term is in violation of *Brulotte*).

¹²⁹ See *Kimble*, 135 S. Ct. at 2408 (expressing that amortization agreements help cash-strapped licensees offset high upfront costs and stimulate new products and inventions to come to market).

¹³⁰ See *id.* (demonstrating how amortization agreements help parties balance economic uncertainties among them).

¹³¹ See Leaffer, *supra* note 6, at 163 (describing that royalty arrangements that extend beyond the patent term may have a pro-competitive effect).

¹³² See *Kimble*, 135 S. Ct. at 2408 (listing multiple patent arrangements as an alternative way to circumvent the bright-line *Brulotte* rule).

¹³³ See *id.* (distinguishing that the patent term limit does not bar other classifications of intellectual property such as trademarks and trade secrets); see also Long, *supra* note 104 (emphasizing *Kimble* decision).

¹³⁴ See Nabulsi & Belt, *supra* note 98 (explaining that the royalty rate cannot exceed the rate applied during the patent term period).

¹³⁵ See Lovenworth & Dolak, *supra* note 8 (describing an alternative solution to *Kimble*'s decision which disregards contracts that extend royalties beyond the patent term).

3. Hybrid Arrangements

Another alternative route are hybrid agreements where the license of a patent and the use of a non-patented right are tied together, but royalties are collected only on the non-patented right, after the patent's expiration.¹³⁶ Under this arrangement, the licensor provides technical support, or some other source of value, to the licensee throughout the term of the license, which may extend beyond the term of the patent.¹³⁷ This type of structure, however, generally requires lower royalty rates or payment structures for the period after the patent expires in order to survive court scrutiny.¹³⁸ Moreover, the license agreement should make clear what consideration is being provided for the post-expiration period and should also emphasize that the lower rate reflects the fact that the patent has expired and thus no longer has value.¹³⁹ Parties may elect to use this as an alternative way to circumvent the bright-line *Brulotte* rule.¹⁴⁰

4. Business Arrangements

The Court further noted that parties could enter into something other than a license agreement.¹⁴¹ There is no bar to business arrangements other than royalties, such as a joint venture as an alternate vehicle to commercialize an invention.¹⁴² These can be particularly relevant in regards to milestone payments or changes to the royalty rate triggered by real world events related to the commercialization of the patented technology.¹⁴³ This type of

¹³⁶ See *Kimble*, 135 S. Ct. at 2408 (referencing hybrid agreements as another way to structure royalty agreements without impinging on *Brulotte*).

¹³⁷ See *Lovenworth & Dolak*, *supra* note 8 (explaining how parties structure terms of a hybrid agreement).

¹³⁸ See *Long*, *supra* note 104 (highlighting that royalties received may not reflect licensing use beyond the term limit).

¹³⁹ See *Nabulsi & Belt*, *supra* note 98 (emphasizing the importance of careful drafting of hybrid licensing agreements).

¹⁴⁰ See *Kimble*, 135 S. Ct. at 2408 (explaining that parties have options beyond the rigid *Brulotte* rule).

¹⁴¹ See *id.* (pointing to joint ventures as a good alternative to circumvent the bright-line *Brulotte* rule).

¹⁴² See *id.* (offering joint ventures and other business arrangements as an alternate way of getting around *Brulotte*).

¹⁴³ See *Nabulsi & Belt*, *supra* note 98 (providing milestone payments as a way to

agreement may be desirable and advantageous to parties who are part of a joint venture agreement in which the licensor maintains an active role in helping with marketing, manufacturing, product development, and the like.¹⁴⁴ To this extent, parties can the risks and rewards of commercialization, well beyond the patent term limit.¹⁴⁵

In effect, all of these agreements require creativity and must be tailored according to parties' particular needs.¹⁴⁶ All four routes promote parties to engage in licensing agreements that utilize various tactics to circumvent the burdens of the bright-line *Brulotte* rule.¹⁴⁷ In doing so, licensors can still absorb patent revenues well beyond the term-limit.¹⁴⁸ This encourages business transactions and spreads risk and cost over a longer royalty payment period.¹⁴⁹ Moreover, all four strategies offer efficient and modern ways to meet the challenges of today's global economic marketplace.¹⁵⁰

D. Cautionary Drafting Considerations

A number of concerns must be considered when structuring royalty contracts.¹⁵¹ First, it is important for parties to carefully review the "Terms and Termination" section of the contract.¹⁵² This

structure a business arrangement).

¹⁴⁴ See Nabulsi & Belt, *supra* note 98 (describing how joint ventures can help parties share the risks and rewards of licensing agreements).

¹⁴⁵ See Nabulsi & Belt, *supra* note 98 (highlighting how joint ventures are an alternate way to get around the bright-line *Brulotte* rule).

¹⁴⁶ See Wilkof et al., *supra* note 88 (stressing the importance of careful and creative drafting of license agreements within the parameters of the law).

¹⁴⁷ See *Kimble*, 135 S. Ct. at 2408 (listing multi-patent arrangements as an alternative way around the bright-line *Brulotte* rule).

¹⁴⁸ See *id.* (illustrating how these alternative routes allow licensors to achieve similar ends as petitioned for in *Kimble*).

¹⁴⁹ See Nabulsi & Belt, *supra* note 98 (suggesting that such licensing agreements allow parties to spread and reallocate the risks and rewards of commercialization).

¹⁵⁰ See Wilkof et al., *supra* note 88 (emphasizing the efficiency and elasticity of the aforementioned licensing agreements as a way to work around *Brulotte*).

¹⁵¹ See Hall, *supra* note 105 (listing issues to consider when drafting licensing agreements).

¹⁵² See Hall, *supra* note 105 (explaining that virtually any company can make a mistake in the terms and conditions of a license agreement). Regular audits of technology license agreements may produce considerable savings by eliminating un-

section should be read in conjunction with the other identified clauses.¹⁵³ Next, it is important for parties to review the “License Grant” clause, which will identify specifically what has been licensed under the agreement.¹⁵⁴ This is of particular importance because some “License Grant” clauses may limit the contract to only patented technology with the non-patentable material occurring under a separate agreement.¹⁵⁵ It is extremely important to review this clause carefully where the license grant applies to both patents and technical know-how, so that royalty obligations continue beyond the term of the last expiring patent.¹⁵⁶ These agreements call for a two-tier royalty schedule, where the first-tier royalty obligation will be greater than the second.¹⁵⁷ In effect, any contract that does not provide a two-tier royalty schedule when the license grant applies to both patents and technical know-how, will be considered *per se* unlawful and in strict violation of *Brulotte*.¹⁵⁸ Furthermore, the “Confidentiality” section should be thoroughly reviewed and audited.¹⁵⁹ Depending upon the language of the aforementioned sections, passage of technical know-how into the public domain may negate the need to pay royalties.¹⁶⁰ Therefore, regular audits of technology license agreements may produce considerable savings by eliminating un-

necessary patent royalty payments. *Id.*

¹⁵³ See Hall, *supra* note 105 (recognizing the importance of auditing the Terms and Conditions Clause against the context and spirit of the entire licensing agreement).

¹⁵⁴ See Hall, *supra* note 105 (stressing the purpose of a License Grant Clause and the importance of auditing it).

¹⁵⁵ See Hall, *supra* note 105 (indicating what may or may not be covered within License Grant clauses).

¹⁵⁶ See Nabulsi & Belt, *supra* note 98 (highlighting that royalties received after the patent term expires must be set at a lower rate than pre-expiration because the value of the license is construed as having diminished).

¹⁵⁷ See Hall, *supra* note 105 (describing how business arrangements provide legally acceptable workarounds to *Brulotte*).

¹⁵⁸ See Hall, *supra* note 105 (emphasizing that if royalties received during the second tier—post the expiration date—exceed the first-tier, then the parties are in violation of *Brulotte*).

¹⁵⁹ See Hall, *supra* note 105 (expressing the importance of reviewing the Confidentiality section, in order to determine if any of the licensed technical know-how has entered the public domain).

¹⁶⁰ See Hall, *supra* note 105 (explaining that depending upon the language of the License Grant, Confidentiality, and Royalty Payments sections, passage of technical know-how into the public domain may negate the need to pay royalties).

essary patent royalty payments.¹⁶¹

E. Assessing How The Alternate Routes Work Around Brulotte

The Supreme Court's ruling in *Kimble*, demonstrates that the Court will adhere to the doctrine of precedent, even if the soundness of the previous decision is in doubt.¹⁶² Moreover, there is an even higher bar for overruling precedent based on statutory interpretation.¹⁶³ Yet, the bench took the liberty to suggest the aforementioned four ways parties can draft licensing agreements without impeding on *Brulotte*.¹⁶⁴

Amortization agreements give parties ways to work around *Brulotte* because parties set a royalty based on sales during the patent term.¹⁶⁵ *Brulotte* imposes a restriction on profits received beyond the patent term.¹⁶⁶ Under an amortization plan, although parties continue to contract beyond the patent term, post-expiration payments remunerate from the amount set during the patent term, not beyond it.¹⁶⁷ *Brulotte*, restricts parties from forming agreements where post-expiration payments are dependent on post-expiration sales.¹⁶⁸ Therefore, amortization agreements do not violate *Brulotte*.

¹⁶¹ See Hall, *supra* note 105 (warning about a potential pitfall for the unwary that failure to run confidentiality audits may lead to unnecessary royalty expenses).

¹⁶² See *Kimble*, 135 S. Ct. at 2415 (pointing the moving party had failed to meet the high bar for disturbing the Court's previous decision on this issue). The reason for that is that usually it is "more important that the applicable rule of law be settled than that it be settled right." *Id.* at 2409 (citing *Burnet v. Coronado Oil and Gas Co.*, 285 U.S. 393, 406 (1932)).

¹⁶³ See *id.* at 2418 (Alito, J., dissenting) (recognizing that statutes are promulgated by the legislature; therefore, the Court would be exceeding its authority by overturning laws enacted by Congress). "[S]tatutory interpretation decisions [are] nearly impervious to challenge." *Id.*

¹⁶⁴ See *id.* at 2408 (indicating ways parties can structure their agreements that will help them achieve similar desirable results).

¹⁶⁵ See *id.* (citing instances when debt amortization may lead to better risk allocation and incentives to both licensees and patent holders).

¹⁶⁶ See *Brulotte*, 379 U.S. at 31 (explaining the Supreme Court's landmark holding that royalty agreements cannot be enforced pursuant to the expiratory period).

¹⁶⁷ See *Kimble*, 135 S. Ct. at 2408 (explaining that such amortization agreements help cash-strapped licensees in the short-term and allocating risk in the long-term).

¹⁶⁸ See *Brulotte*, 379 U.S. at 33 (distinguishing between amortization agreements and *Brulotte*).

In turn, multi-patent agreements are permitted simply because *Brulotte* never banned such arrangements.¹⁶⁹ The gravamen of *Brulotte* was set on extending royalties for a single patent beyond the expiration period.¹⁷⁰ Thus, where a large portfolio of patents is licensed, royalties may run for all patents in the portfolio until the expiration of the last patent in the portfolio is set to expire.¹⁷¹

Likewise, *Brulotte* poses no bar when the license of a patent and the use of a non-patented right are tied together, but royalties are collected only on the non-patented right after the patent's expiration.¹⁷² *Brulotte* restricts parties from receiving payments beyond the statutorily promulgated term limit for patents—not other kinds of intellectual property.¹⁷³ Therefore, such hybrid agreements are harmonious with *Brulotte*.¹⁷⁴

Finally, *Brulotte* is no bar to business arrangements to defer payment or create joint enterprises.¹⁷⁵ These arrangements offer a separate vehicle for parties to navigate around the precedent.¹⁷⁶ Thus, similar to amortization agreements, hybrid arrangements and multi-patent agreements—business arrangements are not barred by

¹⁶⁹ See *id.* (citing a second way to get around *Brulotte*, by extending royalties until the last-to-expire of a patent portfolio); see also Crouch, *supra* note 104 (underscoring that “[t]he ‘Licensed Patents’ are thus normally expressly defined to be ‘anything related’ to the original patents”).

¹⁷⁰ See *Brulotte*, 379 U.S. at 30 (describing a combination of patents with various expiration dates obtained for the purpose of hop growing and harvesting equipment).

¹⁷¹ See Hall, *supra* note 104 (pointing to another workaround drafting option for parties to consider when managing a large portfolio of patents).

¹⁷² See Crouch, *supra* note 105 (navigating another way for parties to layer royalty payments and thus allow for post-expiration royalties so long as certain royalties are expressly tied to non-patent rights).

¹⁷³ See Long, *supra* note 104 (distinguishing that the patent term limit does not bar other classifications of intellectual property such as trademarks and trade secrets).

¹⁷⁴ See *Kimble*, 135 S. Ct. at 2405, 2408 (referencing hybrid agreements as another way to structure royalty agreements without impinging on *Brulotte*).

¹⁷⁵ See *id.* at 2408 (indicating that *Brulotte* poses no bar to business arrangements other than royalties). In particular, the majority pronounced that “*Brulotte* poses no bar to business arrangements other than royalties—all kinds of joint ventures, for example—that enable parties to share the risks and rewards of commercializing an invention.” *Id.*

¹⁷⁶ See *id.* (offering joint ventures and other business arrangements as an alternate way of getting around *Brulotte*).

Brulotte.¹⁷⁷ Instead, they offer parties an alternate means to commercialize an invention beyond the patent term.¹⁷⁸

V. Conclusion

For now, *Kimble* clarified that the bright-line rule of *Brulotte* will continue to remain good law. The decision also noted that overturning *Brulotte* would untangle a web of precedent and disrupt separation of power. And doing so would destabilize and complicate the legal principles upon which license drafters rely. Still, the Court left the back door slightly open—by offering ways to work around *Brulotte*. In practice, parties may structure: amortization agreements, patent grouping arrangements, hybrid agreements and business arrangements such as joint ventures—and still receive the same protections had *Brulotte* been overturned. Thus, in effect, *Kimble* signified that *Brulotte* hardly set economic constraints on licensing arrangements nor thwarted other agreements involving ongoing payments for patent rights. In this sense, *Kimble* re-etched the bright-line established by the precedent. But, it still remains critical that parties administer careful audits and cautiously strategize when drafting these agreements. Hence, this approach can help attorneys protect the best interests of their clients during the patent term and beyond.

¹⁷⁷ See *id.* (hinting that parties can find ways around the bright-line rule, ultimately allowing them to achieve the same desired aims as overturning the precedent).

¹⁷⁸ See *id.* (providing parties alternative ways to circumvent *Brulotte*'s bright-line).